

Light-duty trolley operator

Garaga model PATS -specifications

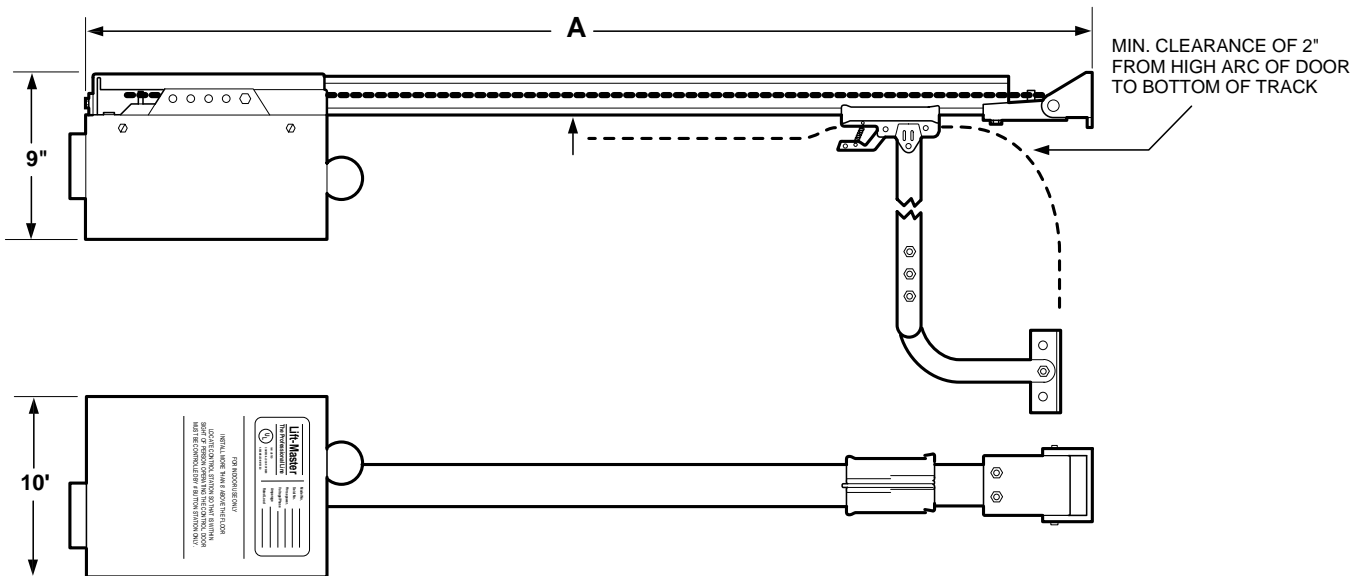

| Door Height | 8' | 10' | 12' |
|---------------|---------------------|----------------------|---------------------|
| A - Dimension | Door Height + 3'-3" | Door Height + 3'-3 " | Door Height + 3'-9" |

STANDARD FEATURES

■ **Model specific:**

Work included – The electric operator will be Garaga Model PATS as manufactured by The Chamberlain Group, Inc. Related work – Door preparation, miscellaneous or structural metal work, field electrical wiring, wire, conduit, fuses, and disconnect switches are in the scope of work of other divisions or trades.

■ **Product:**

Supply Model PATS, light-duty UL and CSA listed, trolley type operator(s) rated 1/2 H.P., 115 Volts, Single Phase.

■ **General:**

Provide electric door operator which meets UL 325 regulations for both residential and industrial applications, complete with 1/2 H.P. electric motor and factory-prewired motor controls, single button OPEN/CLOSE/STOP control station, UL and CSA listed self-monitoring infrared sensing device which is integral to the operator system and accessories required for proper operation.

■ **Electric motor:**

Motor shall be high starting torque, 1/2 H.P. motor with instant reverse and motor overload protection.

■ **Trolley track:**

Heavy-duty steel "I-Beam" configured trolley track with automatic reconnect trolley in case of manual operation.

■ **Safety:**

The operator will include an Automatic Safety Reverse/Automatic Door Stop and non-impact infrared safety device.

■ **Motor starter, controls, enclosures:**

Motor starter shall be solid state circuitry. Motor starting device shall be enclosed in a NEMA 1 enclosure.

■ **Limit switches:**

Fully adjustable, driven linear type limit switch mechanism shall synchronize the operator with the door.

■ **Execution:**

Install the motor operator in accordance with Lift-Master instructions and standards and in compliance with applicable federal, state or local regulations.

■ **Warranty:**

Garaga Commercial Door Operators and accessories shall be warranted to be free of any defect in materials and workmanship for a period of one year.



For more information call Garaga at: (418) 227-2828

or fax Garaga at:

(418) 227-5508

Garaga's e-mail:

info@garaga.com

8500,25th Ave. St-Georges • Québec, Canada G6A 1K5

PATS model

DRAWBAR OPERATOR Garaga light-duty door operator

CUSTOMER _____

PROJECT _____

ARCHITECT / ENGR _____

CONTRACTOR _____

DRAWING NUMBER _____

DATE _____

SHEET _____

OF _____

SHOP DRAWING

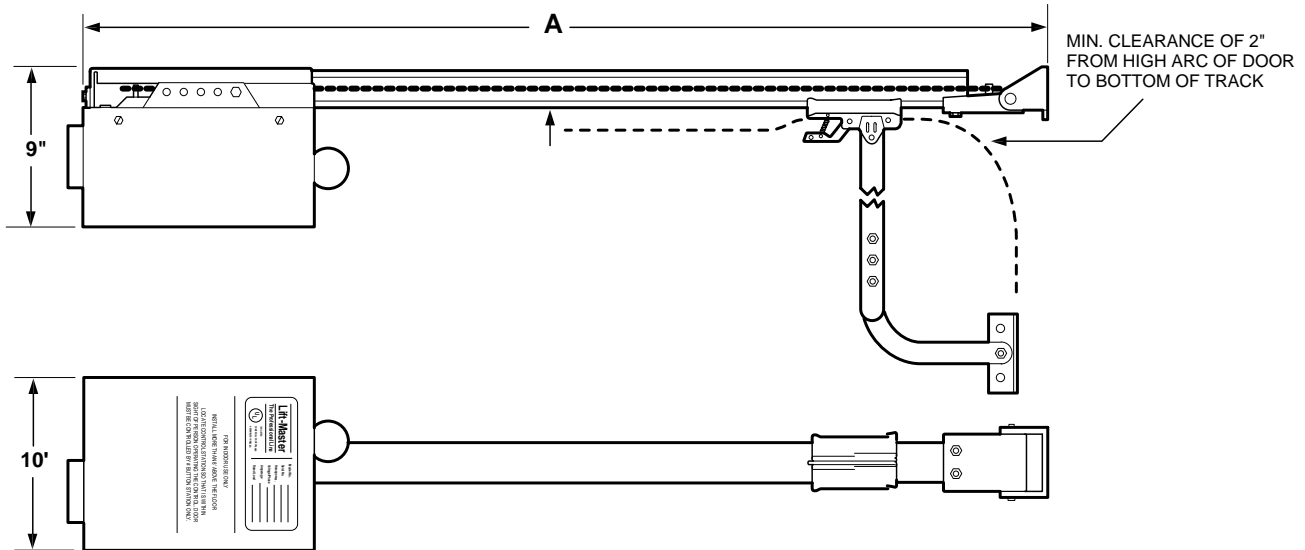

| Door Height | 8' | 10' | 12' |
|---------------|---------------------|---------------------|---------------------|
| A - Dimension | Door Height + 3'-3" | Door Height + 3'-3" | Door Height + 3'-9" |

SPECIFICATIONS FOR ORDERING:

- 1) SUPPLY _____ () GARAGA OPERATOR(S) MODEL _____
_____ HP, _____ VOLTS, _____ PHASE, _____ HERTZ.
- 2) FOR _____ WIDE X _____ HIGH DOOR(S) WITH _____
- 3) SUPPLY _____ () OPEN/CLOSE/STOP CONTROL STATION(S) IN NEMA _____ ENCLOSURE PER OPERATOR.
- 4) SUPPLY AUXILIARY AND OPTIONAL EQUIPMENT AS SPECIFIED BELOW (one per operator unless otherwise noted)

NOTES:

- 1) REFER TO MODEL PATS PRODUCT DATA SHEET FOR GENERAL INFORMATION
- 2) REFER TO DRAWING _____ FOR WIRING DIAGRAM

| MOTOR AMPERAGE RATING | |
|-----------------------|-------------------------|
| HORSE POWER | VOLTAGE - PHASE - 60 Hz |
| | 115-1Ø |
| 1/2 | 5.0 |